

# Changes to Horizon Power Technical Requirements

Relating to Energy Management, and the rollout of Smart Connect Solar across Horizon Power's regional microgrids

# Agenda

Time	Item
3:30	Energy Management Overview
3:45	Changes for Installers
3:50	Updated Technical Requirements
4:30	Questions
5:00	Close

# Energy Management Overview

# What is DER Management System? (DERMS)

Distributed Energy Resource (DER) Management System project aims to establish Horizon Power strategic goal of zero refusals by 2025.

This system is a holistic and scalable approach to its predecessor Onslow DERMS, that will release any constraints on hosting capacity. It comprises of two main components:

- Central Management System (CMS)
  - Hosted in the cloud AWS.
- Secure Gateway Device (SGD)
  - Installed behind the meter as the primary interface.



# Energy Management

Energy Management is the remote monitoring and control of the customers embedded generation to manage load on the power system.

Where previously Horizon has referred to this project / technology as:

- **Feed-In-Management (FIM)**
- **DER Management – DERMS Enabled**
- **DER Management – DERMS Connected**

For the purposes of the following presentation and through the technical requirements documentation, we will supplement the above terms with **Energy Management** and **Energy Management Ready**.

Customers will know this product as **Smart Connect Solar**.



# Why is this required?

Our electricity networks were designed and built for one-way flow of electricity - from power stations to customers' homes and businesses.

Rooftop solar introduces a flow of electricity back into the electricity system, if the energy generated and pushed back into our network is too volatile, it can cause our network to become unstable and cause reliability issues.

**As such, we need a solution to effectively manage this occurrence and maintain grid stability and reliability.**



# What are the benefits?



## Customers



Access to solar now



Reduced bills and increased affordability



Lower carbon communities



## Installers



Increased opportunity for work in regional locations:

- Increased volume, and
- Ability to manage work flow of works



Streamlined applications process



## Horizon



Maintain stable networks



Meet our strategic objectives

- Zero customer solar refusals (2025)
- Decarbonisation of retail emissions (2030)

leading to cleaner, greener networks

# When and Where is this happening?

Smart Connect Solar is coming to all Horizon Power regional microgrids. The solution will be enabled state-wide by December 2024, following a phased rollout approached.

In February 2024, Smart Connect Solar will launch in Carnarvon (Group 1). All applications in Carnarvon thereafter will need to follow the new application process and technical requirements.

Group 2 towns include Karratha, Port Hedland, Derby, Wyndham, Halls Creek, Djarindjin/Lombadina, Kalumburu, Warum, Coral bay, Cue, Meekatharra, Wiluna, Yalgoo, Hopetoun, Laverton, Leonora, Norseman, Camballin/Looma, Ardyaloon, Beagle bay, Bidyadanga, Nullagine

Group 2 will Go Live from Q2 2024





# Where is this solution being implemented? (cont.)

The remaining microgrids that Horizon Power services will follow the following Go Live timing:

- Group 1 – Carnarvon – **February**
- Group 2 – NWIS and all current unrestricted Towns. Towns include Karratha, Port Hedland, Derby, Wyndham, Halls Creek, Djarindjin/Lombadina, Kalumburu, Warum, Coral bay, Cue, Meekatharra, Wiluna, Yalgoo, Hopetoun, Laverton, Leonora, Norseman, Camballin/Looma, Ardyaloon, Beagle bay, Bidyadanga, Nullagine – **Q2 2024**
- Group 3 – Broome – **Q2 2024**
- Group 4 – Exmouth, Sandstone, Denham, Gascoyne Junction, Mount Magnet – **Q3 2024**
- Group 5 – Esperance and Menzies – **Q3 2024**
- Group 6 – Onslow, Fitzroy Crossing, Yungngora, Marble Bar, Kununurra, Lake Argyle – **Q4 2024**



# The new world for customers

By implementing this solution, **customers that want to access solar at any time can do so.**

Compared to systems previously installed, Smart Connect Solar customers will see a slight reduction in their generation outputs across an average year.

Additionally, customers;

- Will need to accept new Terms and Conditions for Smart Connect Solar
  - Gives Horizon the ability to energy manage the device ensuring adequate energy mix and stability
- Ensure they have an adequate internet connection at their home to apply
  - SGD needs a LAN connection into a customer's router / modem
- And work with their installer to ensure that a compatible inverter is selected and installed



# Changes for installers

# What are the changes?

## Required Micro-Accreditation

- To install Smart Connect Solar, installers are required to complete an online micro-accreditation training course
- This training will be hosted by the Clean Energy Council and SwitchDin Academy websites and is **available now**
- The training will always be available on these websites, provided at no cost, and will take about an hour to complete both modules

## Changes to the application process

- Customers will start preliminary parts of the application process.
  - This includes learning about solar, using calculators based on personal consumption data and signing T&C's for Smart Connect Solar
- Upon completion of the 'Solar Ready' process, customers will receive a reference number
  - This reference number is mandatory when submitting a RESA for Smart Connect Solar installations, and replaces the RESA number used previously. Customers will need to provide you this number before you can close out technical components of the application.



# What are the changes?

## Changes to approved inverter list

- In the updated application process, you will recognise that only compatible inverter types will be listed when applying for Smart Connect Solar for Basic EG connections, so it's key to have a good understanding of what these are before quoting for your customers.
- From February 2024, manufacturers with some Smart Connect compatible inverters models are Fronius, SMA, GoodWe, Sofar, Sungrow and GroWatt.
- Horizon Power and its partners are working to enable the compatibility of more devices with Smart Connect Solar.
- Please be sure to check exact approved model, type, and size, via the Horizon Power website.
- As new inverters manufacturers and models become enabled, they will be updated on the Horizon Power website.



# Application and installation process

## Smart Connect enabled town

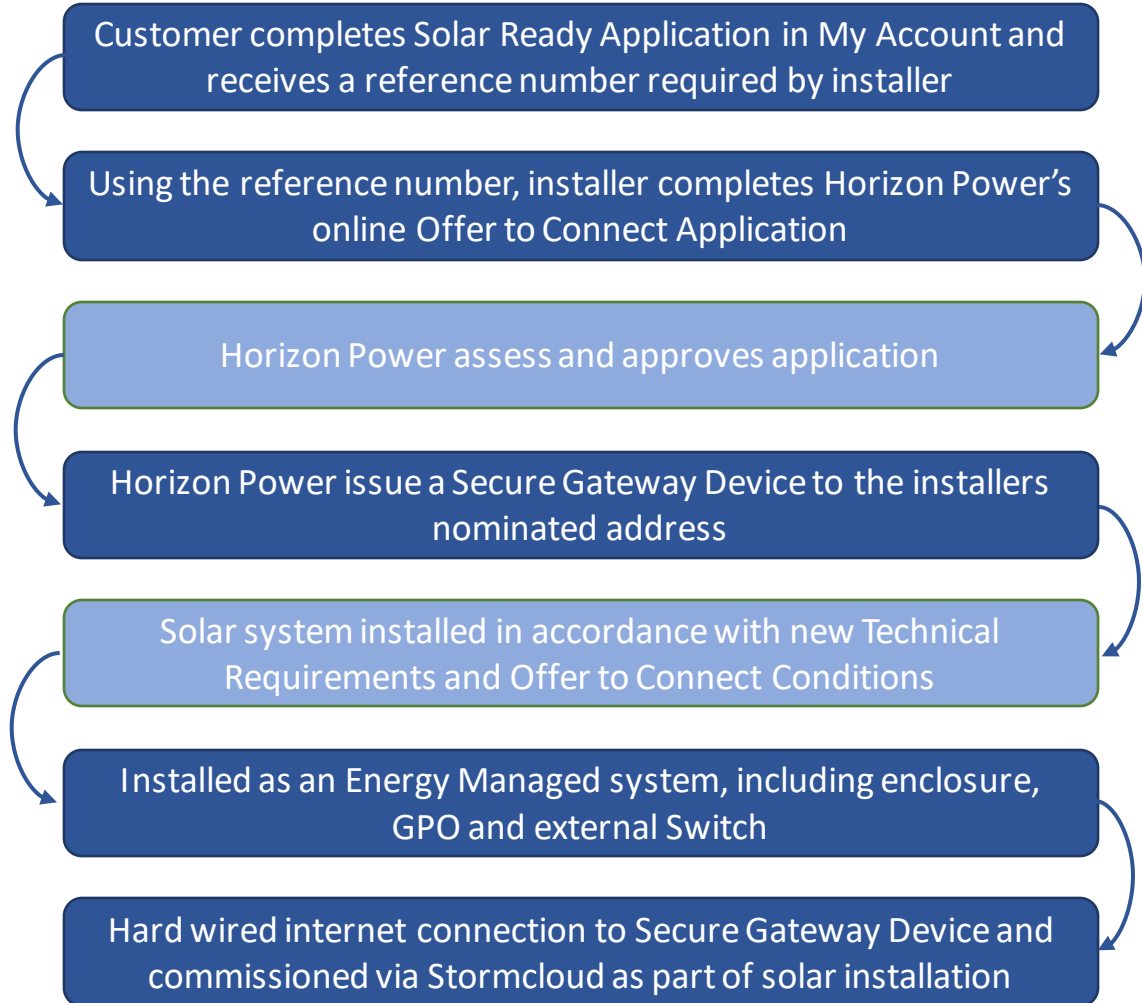

## Available Hosting Capacity town

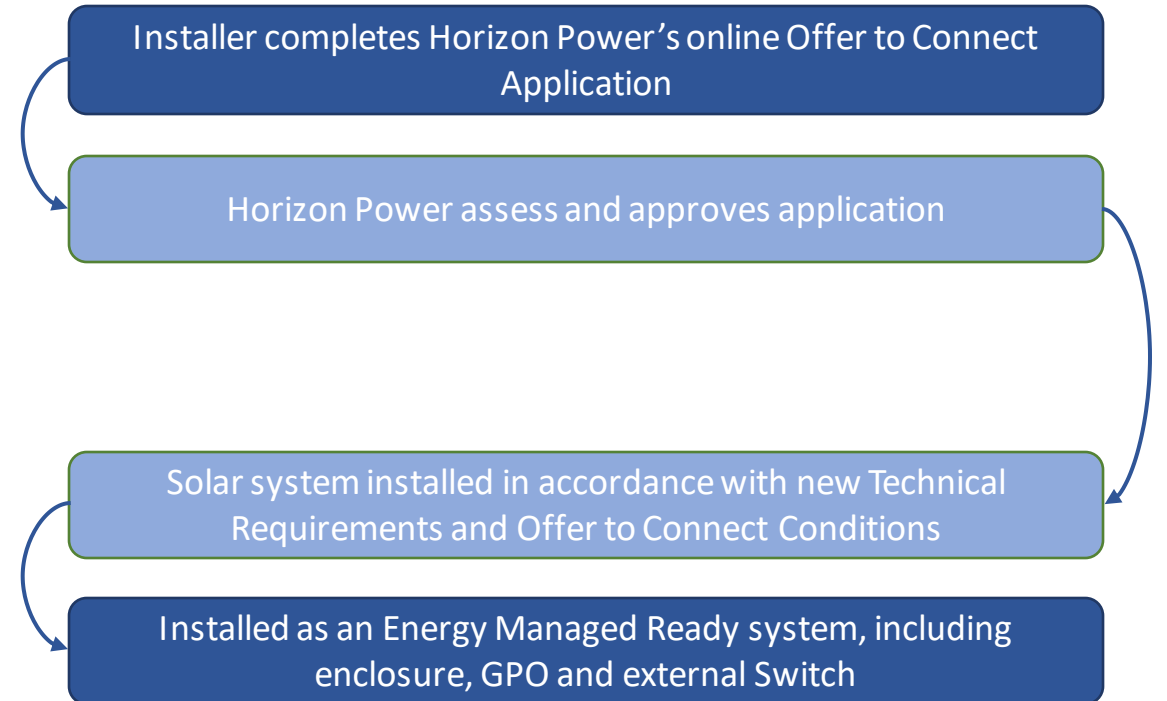

# What are the changes?

## Changes to the Technical Requirements

- The updated Technical Requirements to facilitate Smart Connect Solar will take effect in February 2024.
- The new Technical requirements cover the **Energy Management** requirements and **other technical updates** applicable to all new systems.
- Customers who sign up to Smart Connect Solar require **Energy Management** to be active at the time of connection:
  - Horizon Power will supply a Secure Gateway Device (SGD) to the installer at the time of application approval, for commissioning with the new system.
- *Reminder:* Customers who are not signed up to Smart Connect Solar are required to be **Energy Management Ready** (previously DERMS\_Enabled):
  - Provide and install the required equipment for Energy Management (excluding an active internet connection)
  - Horizon Power will not send a SGD to the installer. SGD commissioning is not required with the new system.
  - Allows for Energy Management to be activated at a future date if required.



# New Technical Requirements



# Overview of Changes by Class

Basic EG (0-30kW*)	LV EG (>30kW)
<p>Energy Management Requirements:</p> <ul style="list-style-type: none"> <li>• Compatible Inverters</li> <li>• Secure Gateway Device (SGD) details</li> <li>• SGD enclosure and GPO with weatherproof switch</li> <li>• Internet Connection</li> <li>• Installation and Commissioning Details</li> </ul>	<p>Updated Energy Management Requirements:</p> <ul style="list-style-type: none"> <li>• Modbus Map</li> <li>• Secure Gateway Device (SGD) details</li> <li>• SGD enclosure and GPO with weatherproof switch</li> <li>• Internet Connection</li> <li>• Installation and Commissioning Details</li> </ul>
<p>Power Systems will no longer be hosting capacity constrained (removed section 1.5 – connections where hosting capacity exhausted)</p>	<p>Power Systems will no longer be hosting capacity constrained (removed sections 1.6 and 4.3.5.4 – connections where hosting capacity exhausted – extended ramp rates)</p>
<p>Change to required AS4777 reconnect frequency setting</p>	<p>Change to required AS4777 reconnect frequency setting</p>
<p>Main switch – circuit breaker required under WASIR</p>	<p>Main switch – circuit breaker required under WASIR</p>
<p>Clarifications in relation to modifications, SPS, and phase balancing and maximum inverter sizes</p>	<p>Clarifications in relation to modifications, energy storage, Renewable Smoothing in the NWIS</p>
<p>Various formatting changes</p>	<p>Various formatting changes</p>

## Basic EG Systems – Energy Management Requirements

1. Select a compatible inverter.
2. Provide an enclosure to house the Secure Gateway Device (SGD). The SGD is provided by Horizon Power.
3. Provide a GPO with external weatherproof switch to power the SGD.
4. Provide a hard-wired internet connection to connect the SGD to the internet.
5. Install and commission the GPO, internet connection, SGD enclosure and SGD, and:
  - Connect SGD to power supply
  - Connect SGD to internet (hard wired)
  - Connect Inverter to SGD (hard wired)
  - Commission the SGD and Basic EG System via SwitchDin's Stormcloud application.

**Reminder:** Customers who are not signed up to Smart Connect solar must be **Energy Management Ready** and provide the above equipment for Energy Management, excluding the hard-wired internet connection. In these cases, Horizon Power will not send a SGD to the installer, and SGD commissioning is not required with the installation.

# Basic EG Systems – Energy Management Requirements

Energy Management Requirement	Customer With Smart Connect Solar	Customer Without Smart Connect Solar (Energy Management Ready, was DERMS_Enabled)
Select a compatible inverter	Required	Required
Provide the SGD enclosure	Required	Required
Provide a GPO with external weatherproof switch	Required	Required
Provide ethernet cable between inverter and SGD enclosure	Required	Required
Provide a hard-wired internet connection	Required	Not Required
Install and commission GPO, SGD enclosure, weatherproof switch	Required	Required
Install and commission SGD	Required	Not Required

# Basic EG Systems – Energy Management Requirements

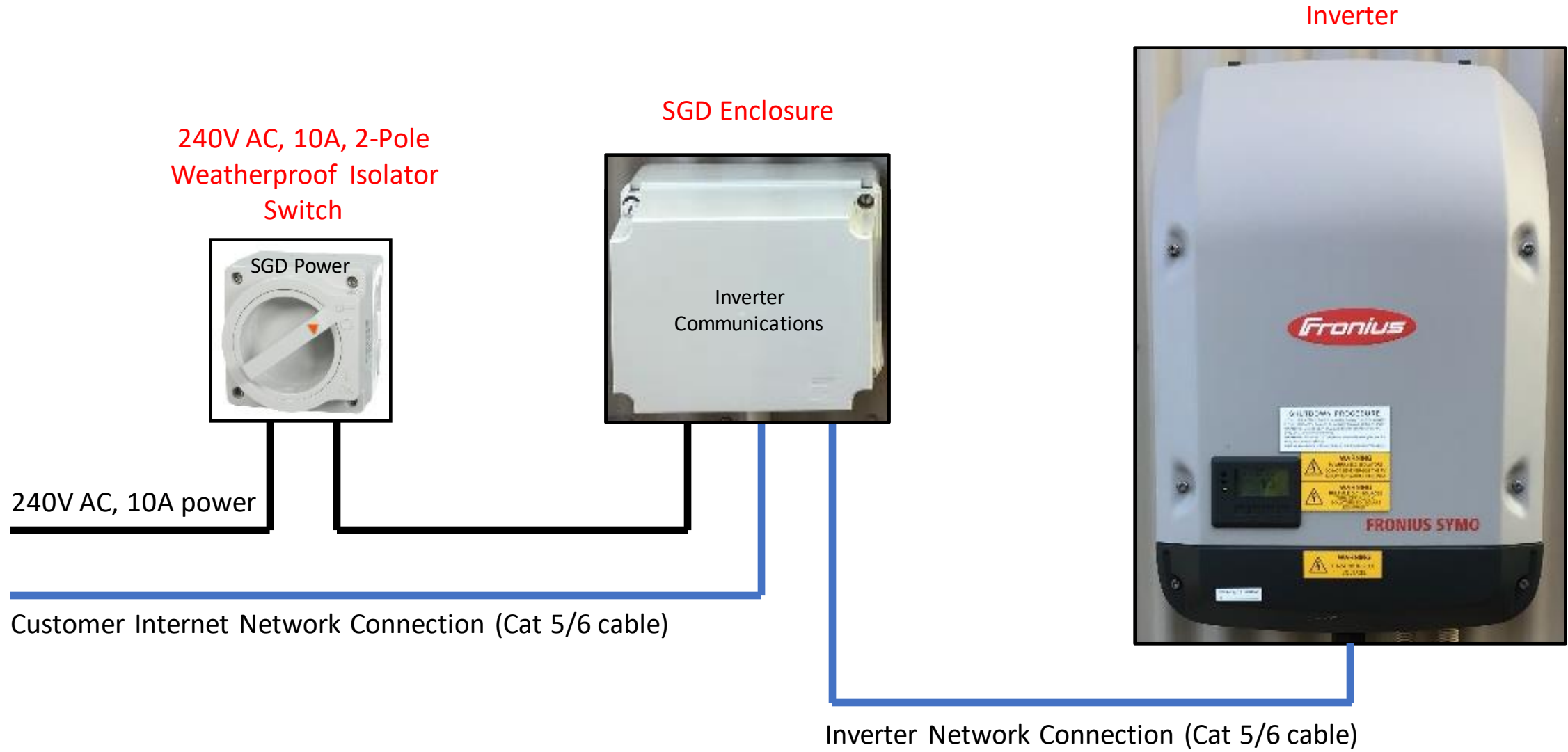

Not to Scale

# Basic EG Systems – Energy Management Requirements

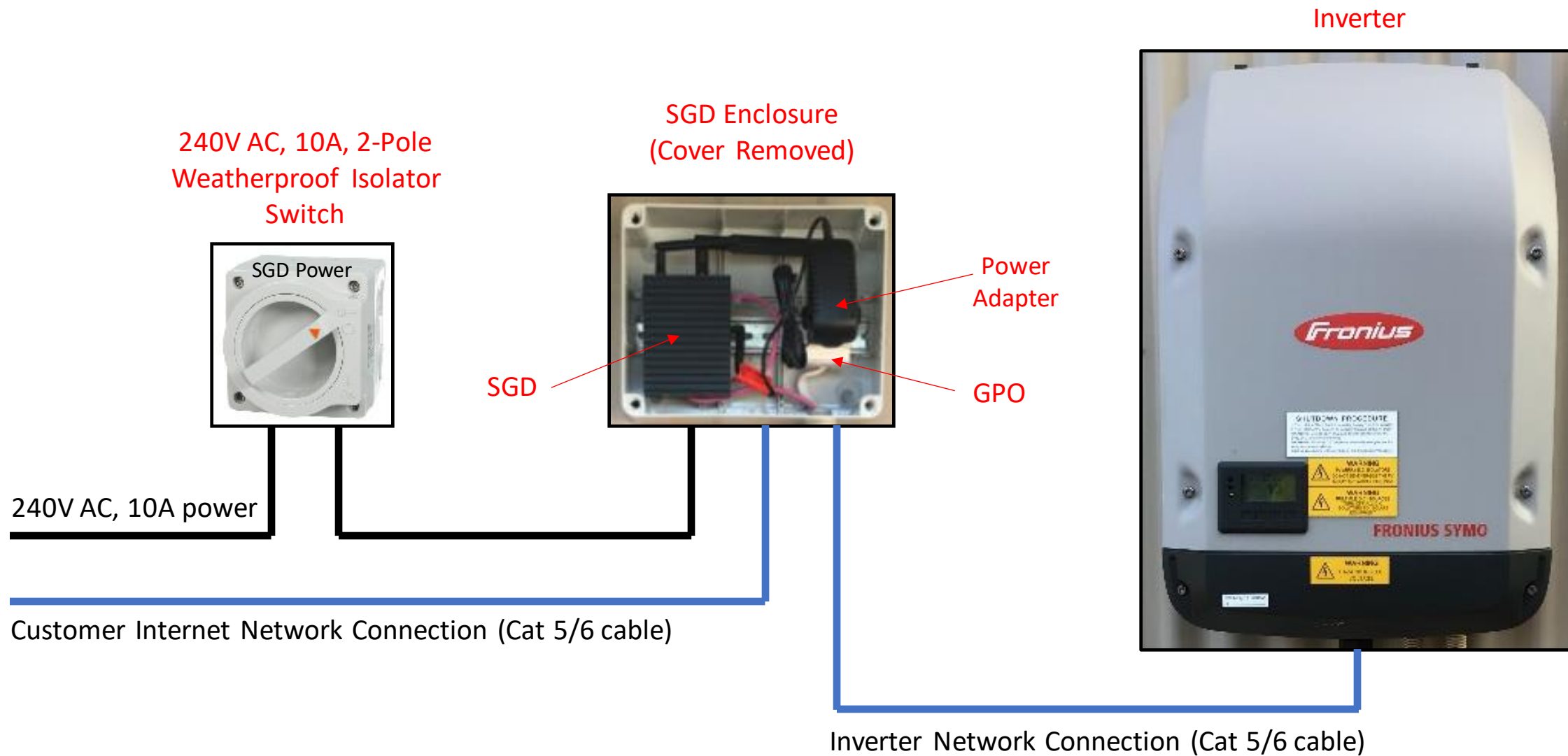

Not to Scale

# Basic EG Systems – Energy Management Requirements

## SGD Network Connections

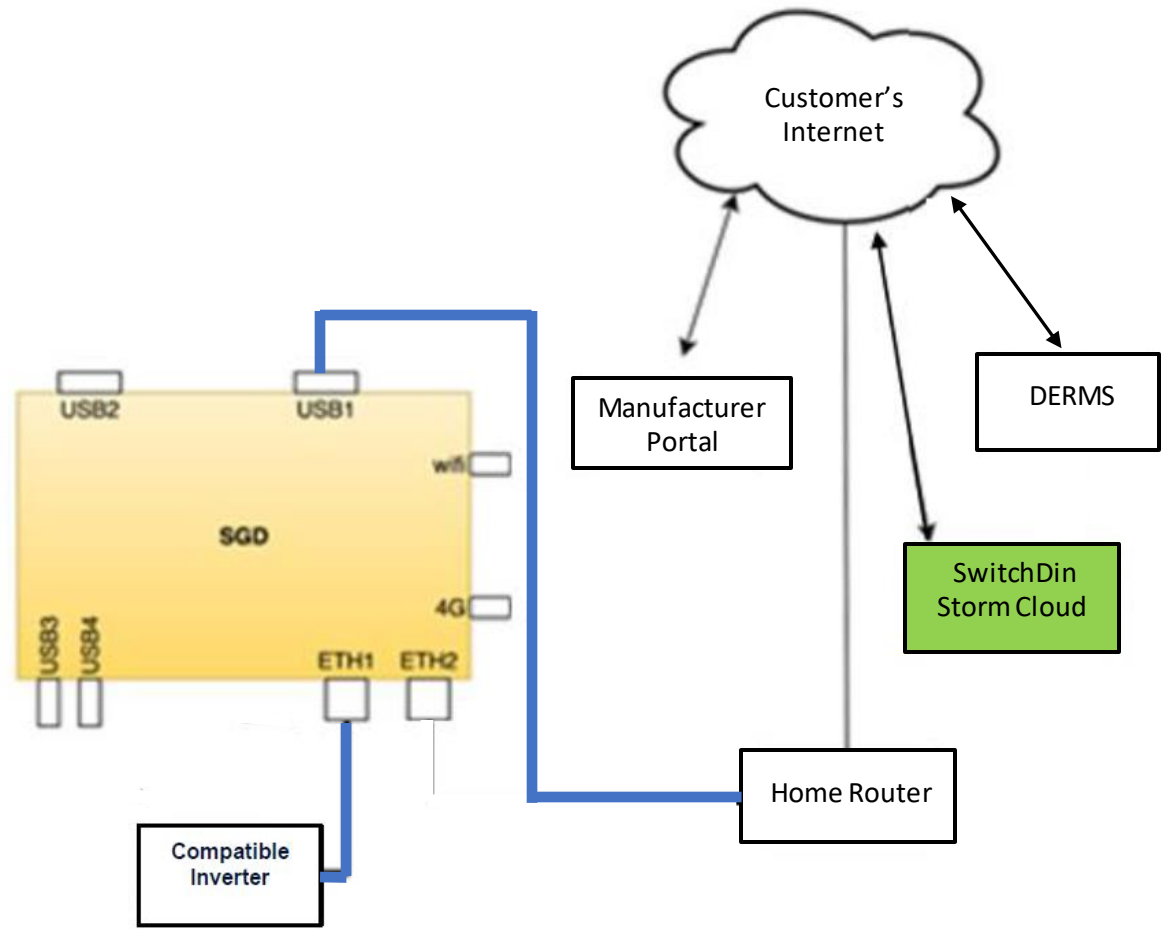

## Secure Gateway Device (SGD)



USB 3: Connect to internet

## Basic EG Systems – Energy Management – Internet Connection

- Hard wired active internet connection at all times (with a Dynamic Host Configuration Protocol (DHCP) service).
- The internet connection allows connection of the SGD to DERMS and connection of the inverters to the inverter manufacturer portal.
- The Basic EG connection may be disconnected during periods where an active internet connection is not available.
- Alternative approaches are possible (eg wifi range extenders) but final connection to SGD must be via a hard wired Cat 5 or Cat 6 cable.

**Reminder:** Customers who are not signed up to Smart Connect solar must be **Energy Management Ready** and provide the equipment for Energy Management, excluding the hard-wired internet connection. In these cases, Horizon Power will not send a SGD to the installer, and SGD commissioning is not required with the installation.

# Basic EG Systems – SGD Enclosure Requirements

- Approx. dimensions of (W) 300 mm x (H) 200 mm x (D) 150 mm or larger, sufficient to house the SGD, GPO and powerpack supply to the SGD
- Allow for one or more DIN rails for connection of the SGD, and GPO
- IP and UV rated to suit local conditions
- Located within 1000mm of inverter, at minimum and maximum heights, and out of direct sunlight
- Easily accessible, with a 750 mm x 750 mm ground level clearance around the SGD enclosure
- Screw sealed or hinged lockable
- Labelled 'Inverter Communications'

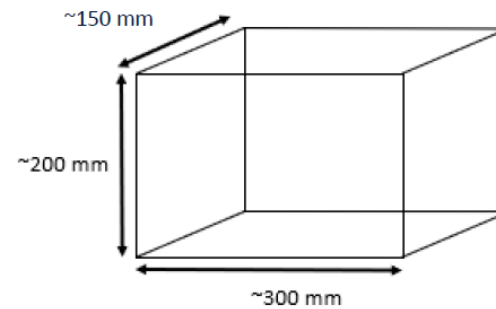

## Enclosure requirements

- Non-transparent
- Approximate dimensions 300 mm (W) x (200 mm (H) x 150 mm (D) sufficient to house SGD, SGD powerpack and GPO with 30 mm spacing on all sides of internal equipment
- IP rated appropriate for local conditions to prevent water / dust ingress
- Suitably UV rated
- Screw sealed or hinge lockable
- Labelled 'Inverter Communications'

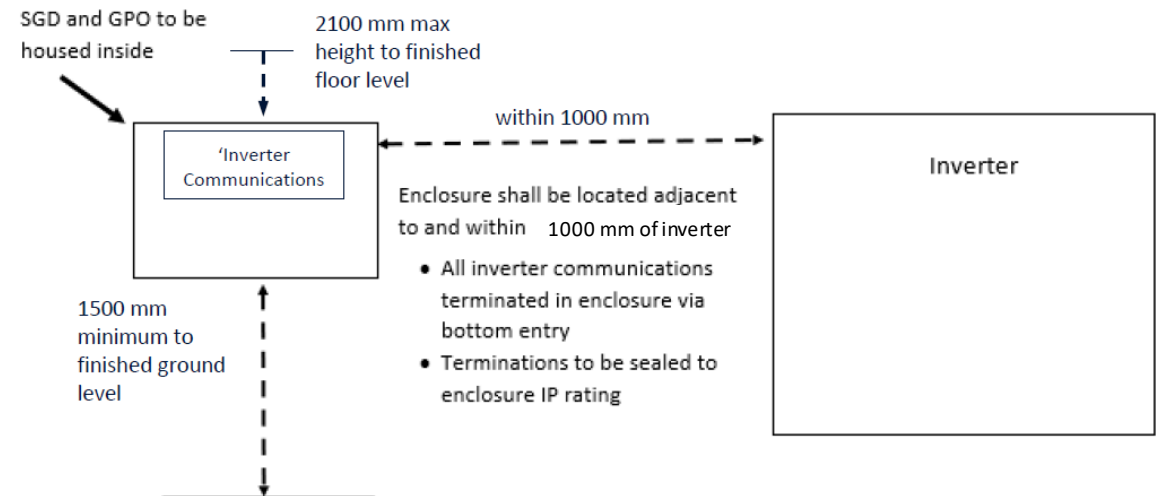



# Basic EG Systems – Energy Management – Compatible Inverters

- For Supported Inverters for Basic EG connections refer to:

[New DER Technical Requirements - Solar & Battery connections  
\(horizonpower.com.au\)](http://horizonpower.com.au)

# Basic EG Systems with Batteries – Energy Management Requirements

- DC Coupled:
  - Inverters must be on approved inverter list (compatible with SGD); and
  - be connected to the SGD.
- AC Coupled or Battery only systems – battery inverters can be either:
  - On approved inverter list and be connected to SGD;
  - Have Modbus Protocol (CSIP-AUS) and be connected to SGD; or
  - Connect to DERMS via an approved API; or
  - Connect to DERMS via an approved Authorised Agent.
- In the case of battery only systems connecting via an approved API or Authorised agent, the SGD and SGD enclosure is not required.

# LV EG Systems – Updated Energy Management Requirements

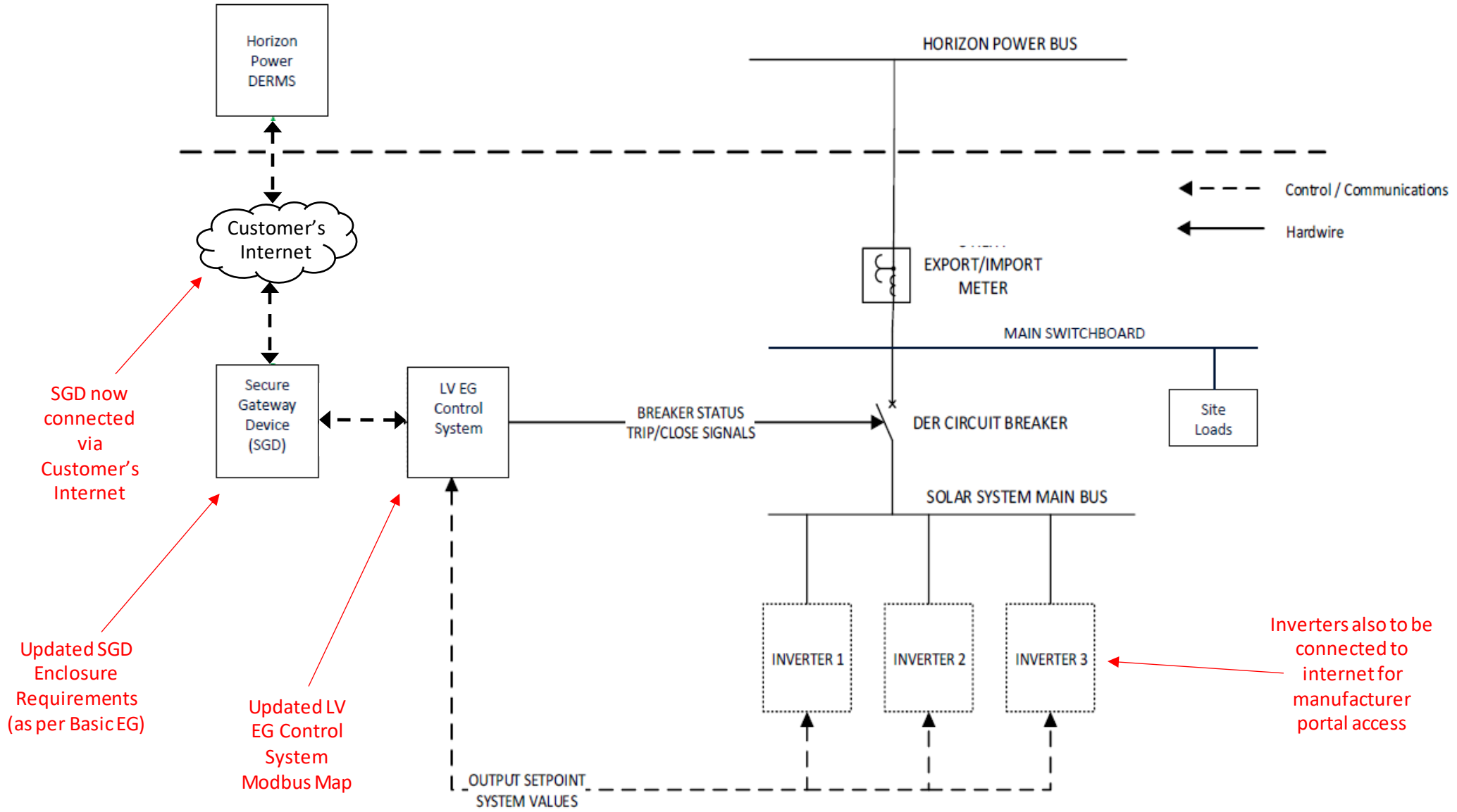

## LV EG Systems – Energy Management – Internet Connection

- Hard wired active internet connection at all times (with a Dynamic Host Configuration Protocol (DHCP) service).
- The internet connection allows connection of the SGD to DERMS.
- Alternative approaches possible (eg wifi range extenders) but final connection to SGD must be hard wired Cat 5 or Cat 6 cable.
- Individual inverters also required to be internet connected for access to manufacturer portal.

# LV EG Connections – Energy Management – Compatible Inverters

- LV EG connections are required to have a single control system interface to the SGD, which allows the use of a wider range of inverter types.
- Also allowed for LV EG connections is direct connection of the SGD to the inverter for single-inverter LV EG connections. In these cases an inverter compatible with the SGD must be selected: [New DER Technical Requirements - Solar & Battery connections \(horizonpower.com.au\)](http://horizonpower.com.au)

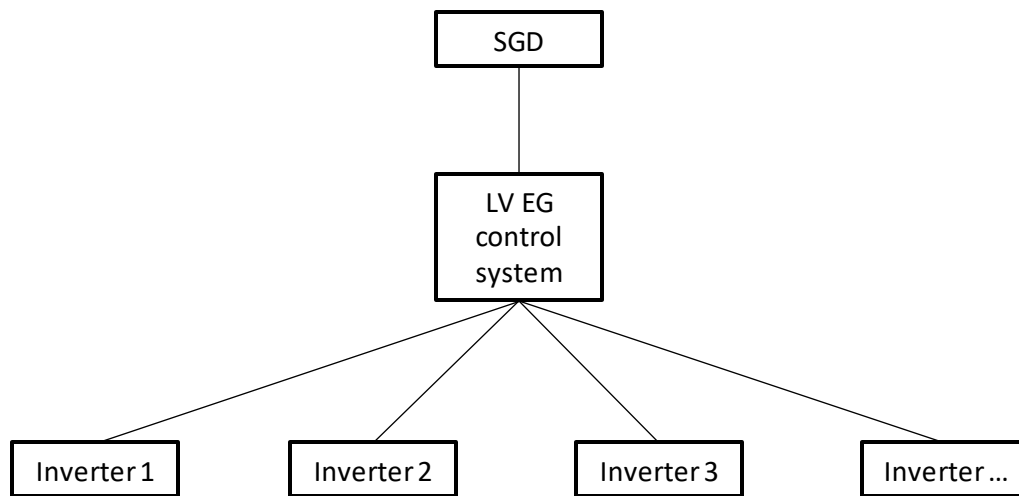

Multiple Inverter Configuration

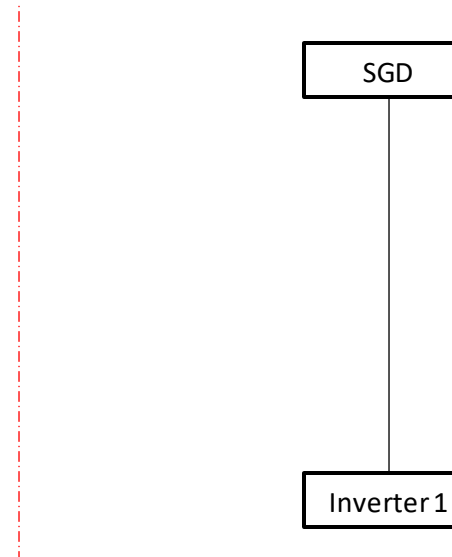

Single Inverter Configuration

# EG Technical Requirements – Australia Region 'C' Settings

- Select and confirm Australia Region C Inverter settings at commissioning.
- Update the upper reconnect frequency to 50.5Hz in Horizon Power systems (see AS4777.2:2020 section 4.7 for further information).
- The upper reconnect frequency will be updated in next version of AS4777.2.



# EG Technical Requirements – Main Switch Requirements

- Installers should design systems to be compatible with the network connection service capacity of the premises.
- Consistent with WA Service Installation Requirements (WASIR), updated April 2023, a main switch consisting of a circuit breaker is required for EG connections (WASIR 11.6.4.3).
- The main switch shall be rated to the connection capacity, and EG system sized such that export limit does not exceed the main switch capacity.



Western Australian Service and  
Installation Requirements | April 2023

# Basic EG Technical Requirements

## Phase Balance Requirements

- Maximum phase imbalance updated to 3 kVA per phase.





# Basic EG Technical Requirements

## Maximum System Capacity

Supply Arrangement (WASIR Connection Service Type)	Basic EG System Type (Inverter Phasing)	Maximum Aggregate System Capacity	
Single-Phase Supply	Single-Phase Inverter	IES without ESS	≤10 kVA
		IES with DC Coupled ESS	
		IES with AC Coupled ESS	IES ≤10 kVA ESS ≤10 kVA
Three Phase Supply	Single-Phase Inverter; or Multiple Single-Phase Inverters	<b>IES without ESS</b>	≤3 kVA per phase
		IES with DC Coupled ESS	≤5 kVA per phase ≤10 kVA in aggregate
		IES with AC Coupled ESS	IES ≤3 kVA per phase ESS ≤5 kVA per phase ESS ≤10 kVA in aggregate
	Three Phase Inverter	IES without ESS	≤10 kVA per phase
		IES with DC Coupled ESS	
		IES with AC Coupled ESS	IES ≤ 10 kVA per phase ESS ≤ 10 kVA per phase ≤50 kVA in aggregate

*IES = Inverter Energy System*

*ESS = Energy Storage System*

## Reminder – Energy Storage Requirements

- Customers can install energy storage for their own requirements.
- Charging from the grid is restricted in accordance with Section 4.3.5.2 for certain towns.
- Renewable smoothing is not required in the NWIS and customers may contact Horizon Power to discuss repurposing smoothing batteries.



# Next Steps

## Next Steps

- The new technical requirements are available at: [New DER Technical Requirements - Solar & Battery connections \(horizonpower.com.au\)](https://horizonpower.com.au)
- The new technical requirements will go live in February 2024
- Before installing your first Smart Connect Solar system, you will need to complete online training via:
  - [The Clean Energy Council](#), where you'll receive 30 CPD points, **OR**
  - [The SwitchDin Installer Academy](#)
- Training for Smart Connect solar consists of two modules and will take about an hour and a half to complete both:
  - Module 1- Smart Connect Solar – Overview
  - Module 2 - Smart Connect Solar – Installation deep dive.

# The Roll Out Schedule

- Group 1 – Carnarvon – **February**
- Group 2 – NWIS and all current unrestricted Towns. Towns include Karratha, Port Hedland, Derby, Wyndham, Halls Creek, Djarindjin/Lombadina, Kalumburu, Warum, Coral bay, Cue, Meekatharra, Wiluna, Yalgoo, Hopetoun, Laverton, Leonora, Norseman, Camballin/Looma, Ardyaloon, Beagle bay, Bidyadanga, Nullagine – **Q2 2024**
- Group 3 – Broome – **Q2 2024**
- Group 4 – Exmouth, Sandstone, Denham, Gascoyne Junction, Mount Magnet – **Q3 2024**
- Group 5 – Esperance and Menzies – **Q3 2024**
- Group 6 – Onslow, Fitzroy Crossing, Yungngora, Marble Bar, Kununurra, Lake Argyle – **Q4 2024**



# Questions