

Pole Base Vegetation Clearing Agreement



I/we _____ of _____

Western Australia, request you not to undertake any fire prevention vegetation clearing in the clearance zone around the base of your electricity poles/structures:

- identified by installed numbered metal tags that correspond to the numbers in Part 1 of the Schedule; and
- that are situated on the property identified in Part 2 of the Schedule,

Until six (6) months have elapsed from the date on which I/we give you written notice to cancel this request.

I/We agree with you that in consideration for your acceptance of my/our request, I/we will maintain the ground in the clearance zone of each pole/structure clear of flammable vegetation and materials, at all times; and:

- release you from any claim that I/we might otherwise have for loss or damage that I/we suffer; and
- indemnify you from any claim that any third party brings against you for loss or damage,

that is caused by or attributable to fire that starts on or escapes from the clearance zone of any pole/structure due to the operation or failure of any of the electrical apparatus or equipment associated with that pole/structure, while this agreement is operative.

I/We agree with you that this agreement takes effect according to its terms:

- despite any earlier agreement made between us including a contributory extension scheme agreement; and
- regardless of any payment I/we make to you by way of a contribution to the maintenance of the poles and structures, including vegetation clearance.

In this agreement the clearance zone means the area shown in drawings:

- M3-1 (Attachment A); and
- M3-2 (Attachment B).

Schedule

Part 1 – Pole/structure details

Part 2 – Property

Submission of this agreement

Please post, email or fax this agreement form to your nearest Horizon Power office (details below)

Regional Centres:

Karratha (Head Office) Stovehill Road KARRATHA WA 6714	PO Box 817 Karratha WA 6714	Ph: (08) 9159 7250 karratha@horizonpower.com.au	Fax: (08) 9159 7288
Port Hedland 18 Anderson Street PORT HEDLAND WA 6721	PO Box 314 Port Hedland WA 6721	Ph: (08) 9173 8282 porthedland@horizonpower.com.au	Fax: (08) 9173 2339
Kununurra Cnr of Messmate Way and Victoria Hwy KUNUNURRA WA 6743	PO Box 916 Kununurra WA 6743	Ph: (08) 9166 4700 kununurra@horizonpower.com.au	Fax: (08) 9166 4720
Gascoyne Mid West Cnr Iles Road and Robinson Street CARNARVON WA 6701	PO Box 825 Carnarvon WA 6701	Ph: (08) 9941 6299 carnarvon@horizonpower.com.au	Fax: (08) 9941 6201
Goldfields Esperance 143 Sims Street ESPERANCE WA 6450	PO Box 148 Esperance WA 6450	Ph: (08) 9072 3400 esperance@horizonpower.com.au	Fax: (08) 9072 3401
Broome 2 - 4 McDaniel Road BROOME WA 6725	PO Box 345 Broome WA 6725	Ph: (08) 9192 9900 broome@horizonpower.com.au	Fax: (08) 9192 9901

Dated:

Signed as a deed under seal by:

In the presence of:

Signature

Signature

Print name

Print name

Address

Occupation

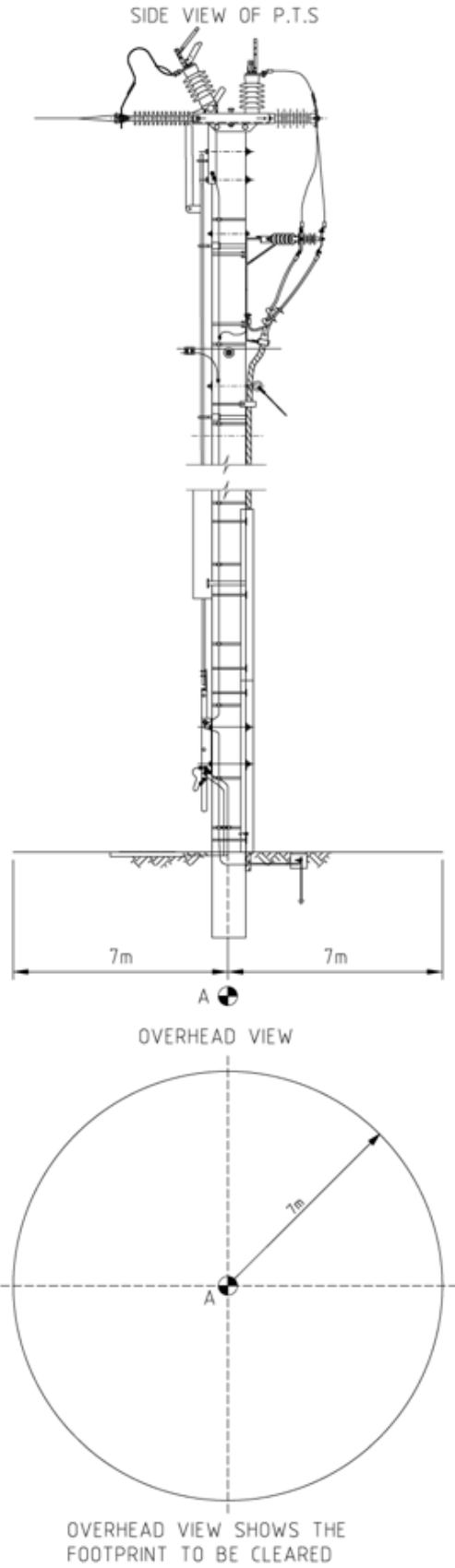

 DISTRIBUTION CONSTRUCTION STANDARDS OPERATIONS	STRUCTURE GROUND CLEARING	REVISION B	DATE AUG 2015
	POLE TOP SWITCH OR ISOLATOR GROUND CLEARING DETAILS	DRAWING No. M3-1	

CASE 1: THREE PHASE POLE

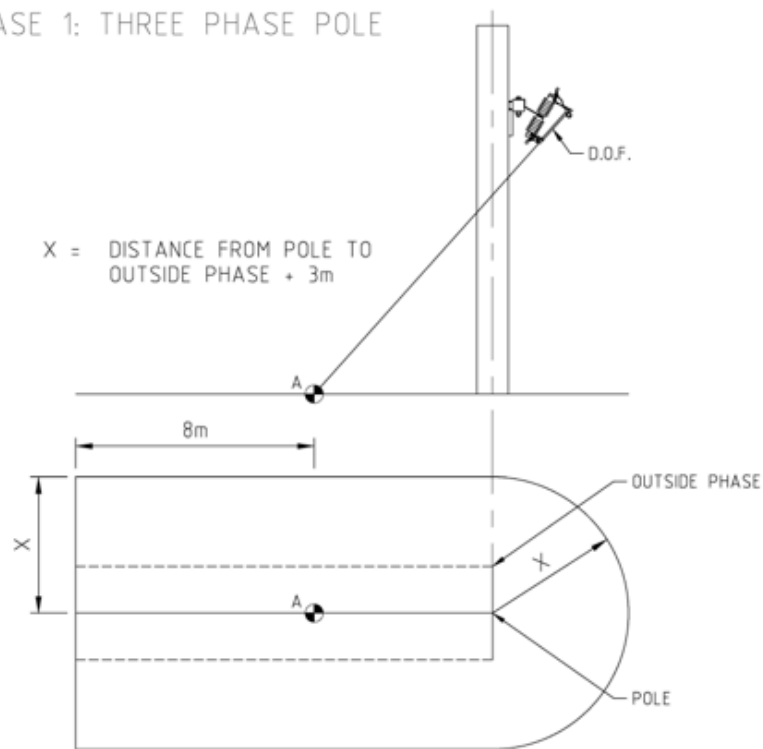

CASE 2: SINGLE PHASE POLE

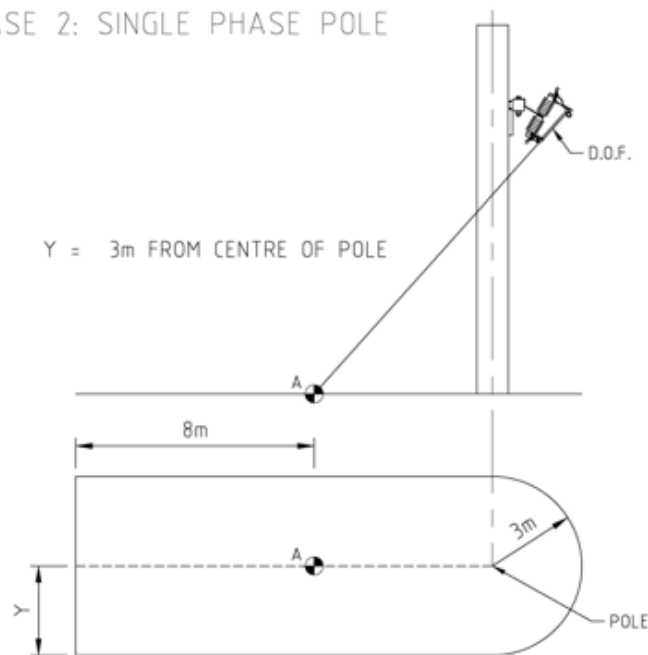

NOTE:

1. POINT A SHALL BE DETERMINED BY FOLLOWING A LINE FROM THE FUSE TO THE GROUND ALONG THE ANGLE OF THE FUSE.
2. FOR THREE-PHASE POLES, POINT A SHALL BE DETERMINED FROM CENTRE PHASE.

 DISTRIBUTION CONSTRUCTION STANDARDS OPERATIONS	STRUCTURE - GROUND CLEARING	REVISION B	DATE AUG 2015
	EXPULSION TYPE DROPOUT FUSE GROUND CLEARING DETAILS	DRAWING No. M3-2	